

Residential Energy Storage

Hope 14.3L - R1 Battery System



S044.SK0020400

Version: 1.0

About this Document

This document describes the installation, electrical connection, operation, commission, maintenance and troubleshooting of Hope 14.3L-R1 Battery System (hereafter simply put Hope14.3L). Before installing and operating Hope 14.3L-R1, ensure that you are familiar with product features, functions, and safety precautions provided in this document.



Table of Contents

1. Product Overview	1
1.1 Product Description	1
1.2 Appearance	1
1.2.1 Dimension (unit:mm)	1
1.2.2 Introduction to the battery operation panel	1
1.3 LCD display screen	3
1.3.1 LCD Icon introduction	3
1.3.2 LCD display information	4
1.3.3 LCD Display parameter setting	5
1.4 Function and Introduction	6
1.5 Battery software upgrade	7
1.5.1 Upgrade via USB	7
1.5.2 Upgrade via Inverter	7
2 Safety	7
2.1 Application	7
2.2 Safety Precautions	8
2.2.1 Environment requirements	8
2.2.2 Operation and Precautions	8
2.3 Warning labels	9
2.4 Emergency Responses	10
3 Storage and Transportation	11
3.1 Storage Requirements	11
3.2 Transportation Requirement	11
4 Installation	11
4.1 Installation Environment	12
4.2 Installation Required Tools	12
4.3 Check	12
4.3.1 Pre-installation Check	12
4.3.2 Check Packing List	13
4.4 Installation	14
4.4.1 Battery Placement	14
4.4.2 Communication Cable Communication	14
4.4.3 Single Battery Installation	15
4.4.4 Battery Capacity Expansion Installation	18
4.4.5 Battery Pack Power Expansion Installation	19
4.4.6 Battery Pack Capacity and Power Expansion Installation	21
5 Power on/off	22
5.1 Power on	22
5.2 Power off	22
6 Maintenance Guide	23
6.1 Preparation	23
6.2 Battery Replacement	23
6.3 System Failure Information List and Trouble Shooting Suggestions	23

7 Technical Specifications.....	25
Appendix 1 Fault code table.....	26
Appendix 2.....	28



1. Product Overview

1.1 Product Description

Hope 14.3L-R1 consists of 280Ah cells which form 51.2V voltage battery module and 16 cells in serial connection (1P16S). Max parallel number is 48pcs which can expand the capacity to up to 686KWH. Support LCD screen display and setting. For meeting the needs of home storage power supply, batteries and inverters are combined to be home storage solar system with protection functions such as overcharge, over-discharge, over current, over temperature, and short circuit. For serve customers properly, the company has a big data server to facilitate after-sales maintenance, and equipped with APP display function, remote upgrade function and U-disk upgrade function. Additionally, an external integration LCD display allows customers to check the different batteries conditions and read the different batteries details more conveniently.

1.2 Appearance

Hope 14.3L-R1 consists of battery module (including cells and mechanical parts), battery management system (BMS) as well as power switch and communication terminals. Product appearance as below.

1.2.1 Dimension (unit:mm)

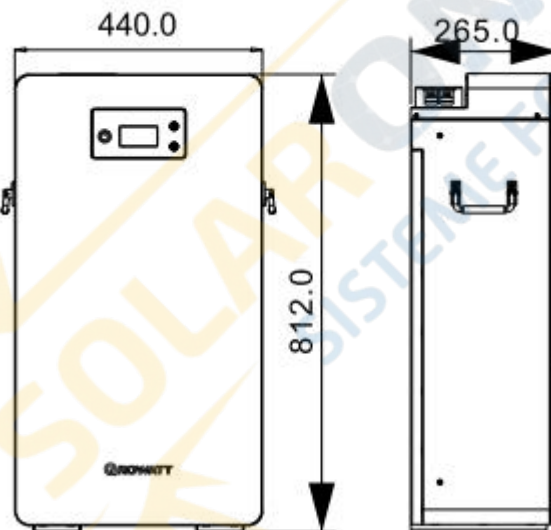

Figure 1: Battery size diagram

1.2.2 Introduction to the battery operation panel

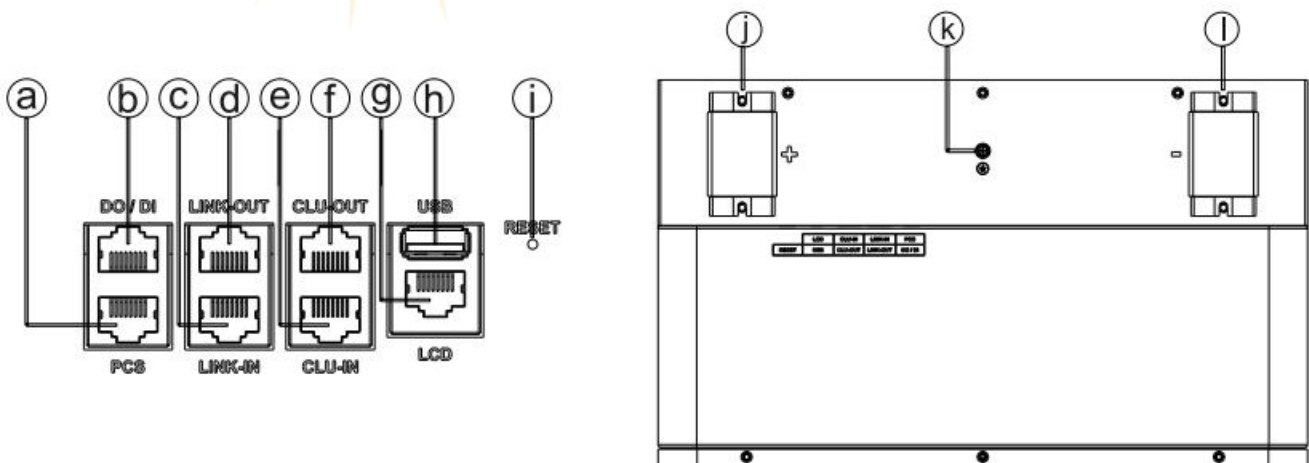

Figure 2: Introduction to the battery operation panel

Location	Port	Function
a	PCS	Communicate with the inverter
b	DO/DI	Emergency signal output/input port
c	Link-In	battery parallel communication (CAN/WAKEUP/MASTER)
d	Link-Out	battery parallel communication (CAN/WAKEUP/SLAVE)
e	Clu-In	clustering communication
f	Clu-Out	clustering communication
g	LCD	For linking external integration LCD
h	USB	USB interface for system upgrade, a mobile phone can't be charged
i	Reset	Pressing triggers MCU reset
j	P+	Battery Positive
k	GND	GND
l	P-	Battery Negative

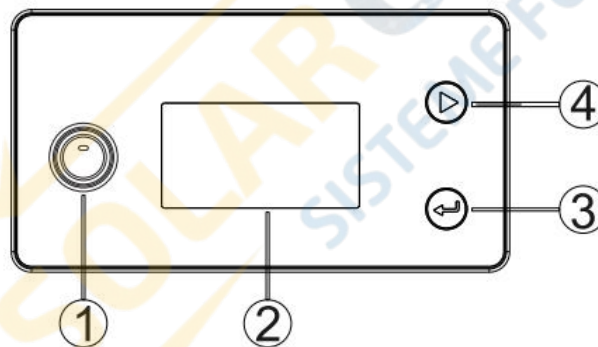

Figure3: LCD Panel drawing

No.	Name	Color	Description
1	ON/OFF	Green	Power on/off Button
2	LCD		Displaying battery data
3	Enter/Return		Enter and return
4	UP		page turning

1.3 LCD display screen

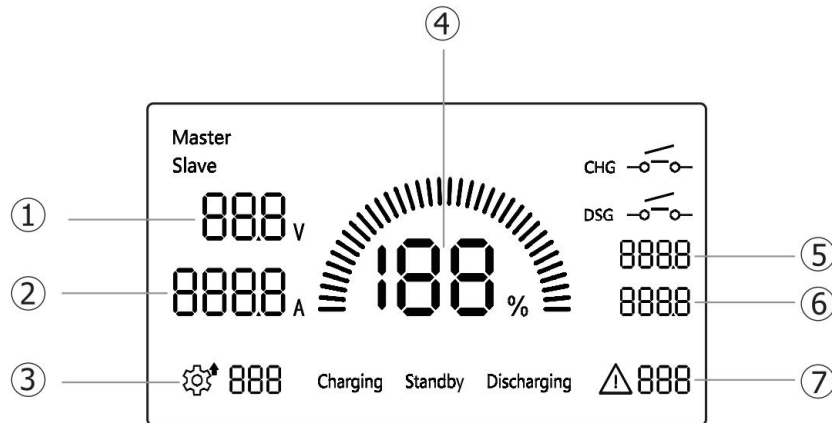

Figure 4: LCD diagram

1.3.1 LCD Icon introduction

Icon	functional description
	Displays the battery SOC and battery upgrade progress.
Master Slave	The battery master/slave label is displayed.
888 V	Displays battery voltage.
8888 A	Displays battery current.
	Displays parameters being set.
CHG DSG	Displays the status of the charge and discharge switch.
FCC 8888	Displays full capacity, module cluster address, maximum cell voltage, maximum cell temperature.
CAP 8888	Displays the remaining capacity, parallel address of the module, minimum voltage of the unit, and minimum temperature of the unit.
Charging Standby Discharging	Displays the battery status.
	Display alarm or fault code, fault steady on, alarm blinking, multiple faults or alarms, press the key to switch, fault table see Appendix 1

1.3.2 LCD display information

Press the UP key to switch the LCD information in turn. The displayed information includes voltage, current, SOC, module address and firmware version.

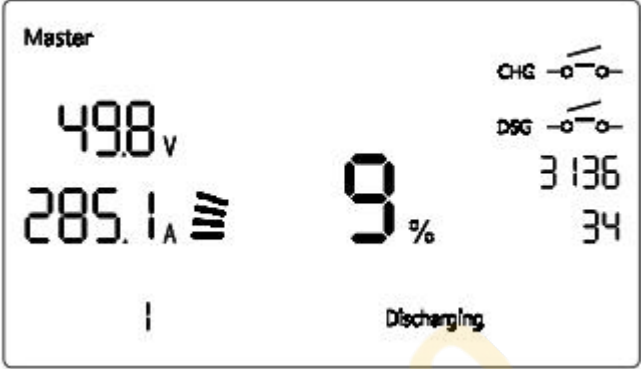
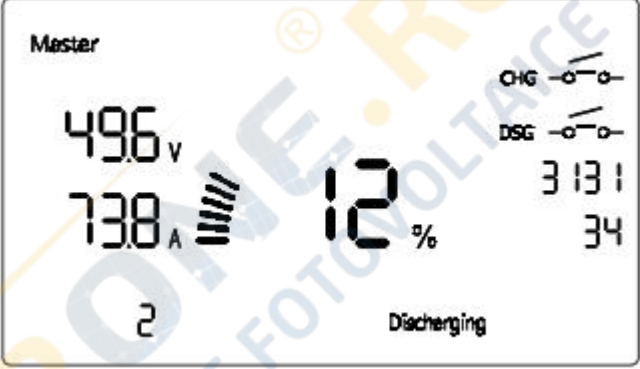
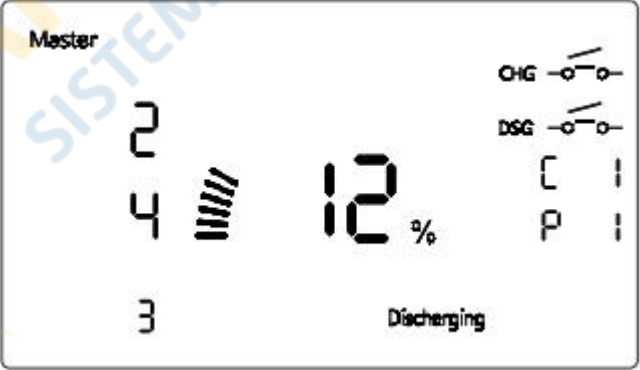
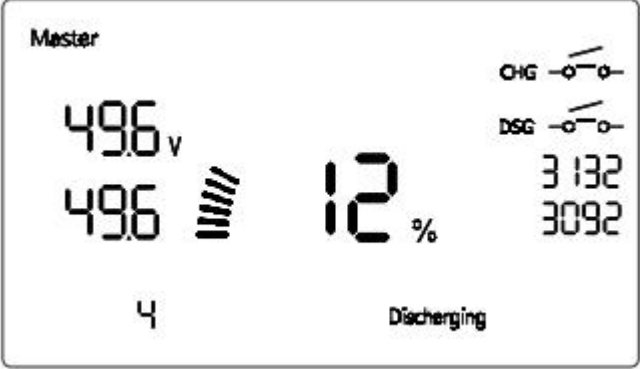
parameter information	LCD display
① Battery voltage(V) ② Battery current(A) ③ Page number ④ Battery SOC(%) ⑤ Maximum cell voltage(mV) ⑥ maximum temperature(°C) ⑦ Alarm or fault code (Default interface, the host displays system summary data, the Slave does not have this page)	 <p>The LCD display for page 1 shows the following information: 'Master' at the top left, '498 V' for battery voltage, '285.1 A' for battery current with a bar graph indicator, '9 %' for SOC, '3136' for maximum cell voltage, '34' for maximum temperature, and 'Discharging' at the bottom. On the right side, there are two status indicators: 'CHG' and 'DSG', each with a switch symbol.</p>
① Battery voltage(V) ② Battery current(A) ③ Page number ④ Battery SOC(%) ⑤ Maximum cell voltage(mV) ⑥ Maximum temperature(°C) ⑦ Alarm or fault code (When you are a slave, the Master displays Slave)	 <p>The LCD display for page 2 shows: 'Master' at the top left, '496 V' for battery voltage, '738 A' for battery current with a bar graph indicator, '12 %' for SOC, '3131' for maximum cell voltage, '34' for maximum temperature, and 'Discharging' at the bottom. On the right side, there are two status indicators: 'CHG' and 'DSG', each with a switch symbol.</p>
① Cluster number ② parallel number ③ page number ④ Battery SOC(%) ⑤ Cluster address ⑥ parallel address ⑦ Alarm or fault code	 <p>The LCD display for page 3 shows: 'Master' at the top left, '2' for cluster number, '4' for parallel number with a bar graph indicator, '12 %' for SOC, 'P' for cluster address, and 'I' for parallel address. At the bottom, it says 'Discharging'. On the right side, there are two status indicators: 'CHG' and 'DSG', each with a switch symbol.</p>
① Battery voltage(V) ② PACK voltage(V) ③ page number ④ Battery SOC(%) ⑤ Maximum cell voltage(mV) ⑥ minimum cell voltage(mV) ⑦ Alarm or fault code	 <p>The LCD display for page 4 shows: 'Master' at the top left, '496 V' for battery voltage, '496' for PACK voltage with a bar graph indicator, '12 %' for SOC, '3132' for maximum cell voltage, and '3092' for minimum cell voltage. At the bottom, it says 'Discharging'. On the right side, there are two status indicators: 'CHG' and 'DSG', each with a switch symbol.</p>

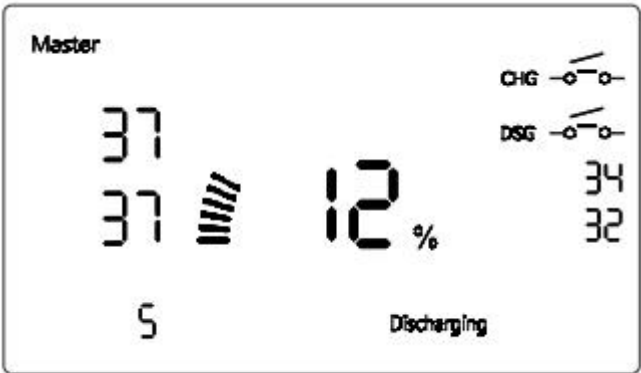
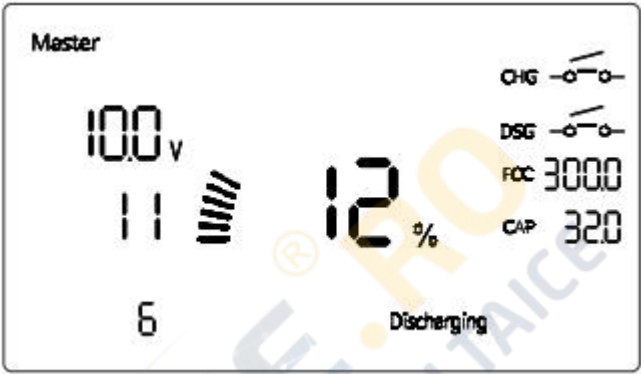
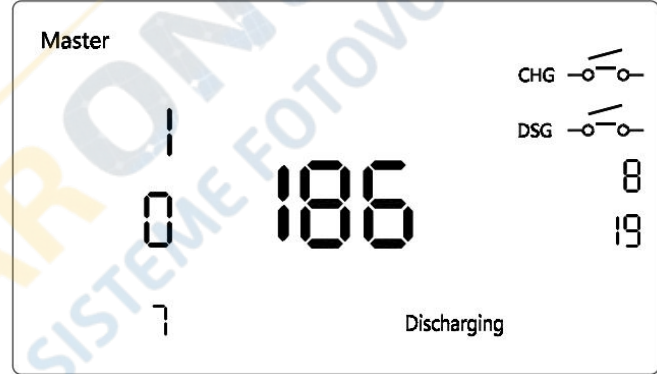
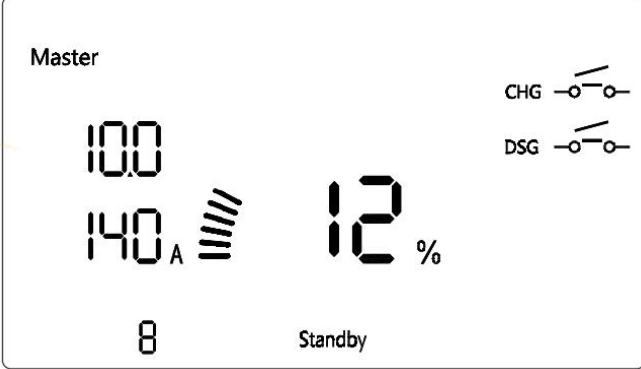
<ul style="list-style-type: none"> ① MOS temperature(°C) ② Environment temperature(°C) ③ Page number ④ Battery SOC(%) ⑤ Maximum temperature(°C) ⑥ Minimum temperature(°C) ⑦ Alarm or fault code 	
<ul style="list-style-type: none"> ① Battery SOH (%) ② Cycles ③ Page number ④ Battery SOC (%) ⑤ Full capacity(Ah) ⑥ Surplus capacity(Ah) ⑦ Alarm or fault code 	
<ul style="list-style-type: none"> ① Hardware version ② Software version ③ Page number ④ Fix version ⑤ Software Date (month) ⑥ Software Date (day) ⑦ Alarm or fault code 	
<ul style="list-style-type: none"> ① Maximum charging current(A) ② Maximum discharge current(A) ③ Page number ④ Battery SOC(%) ⑤ Alarm or fault code 	

1.3.3 LCD Display parameter setting

Set item	describe	settings	
		Growatt (default)	PCS ⚙️ 00 000
		Pylon 1(9600kbps)/Deye	PCS ⚙️ 00 00

001	communication protocol	Pylon 2(115200kbps)	PCS ⚙️ 001	002
		Luxpower	PCS ⚙️ 001	003
		Vision	PCS ⚙️ 001	004
		Energysys	PCS ⚙️ 001	005
		SRNE	PCS ⚙️ 001	006
002	Screen sleep time	LSbt ⚙️ 002	30	Time when the LCD goes to sleep when no key is pressed LCD sleep time: 30 by default. The value ranges from 1s to 255s
003	factory data reset	rfs ⚙️ 003	000	If this parameter is set to 111, battery parameters are restored to factory Settings
004	BMS Control	CEL ⚙️ 004	000	If this parameter is set to 001, The battery can be discharged at temperature.

Setting protocol example. Other items are set in the same way

- 1 Press and hold the [Confirm] button to enter the setting screen. 01 PCS protocol display.
- 2 Press and hold [Confirm] to enter the first digit of parameter setting, [0] 0 0, and press [UP] to switch from 0 to 9.
- 3 Tap [Confirm] to enter the second digit, 0 [0] 0, and tap [UP] to switch from 0 to 9.
- 4 Tap [Confirm] to enter the third digit, 0 0 [0], and tap [UP] to switch from 0 to 9.
- 5 Press and hold [Confirm] to save the Settings and press to exit.

1.4 Function and Introduction

Function	Description
APP Display and Upgrade	Display BMS information and upgrade
CAN communication	2 Circuits, with isolation, One for battery parallel communication, the other for communication with inverter
Battery in Parallel	Max parallel number is 48pcs
SOC Algorithm	Dynamic SOC estimation for battery packs
SOP Algorithm	Based on different temperature, The evaluation capacity of voltage and SOC to the maximum output or maximum input at the next moment
Running Status Display	LED lights to display Green: System running status
Power off	1. Button Shutdown, 2. No Communication Shutdown, 3. Battery Low Voltage Shutdown 4. When Used in Parallel, it Can Be "One Key Shutdown.
Power on	1. Key On, 2. Charge On,

	3. Activate Signal on, 4. When Used in Parallel Can "One Key On".
Balanced Management	Improve the consistency of the voltage of each single battery to protect the battery.
Voltage Detection	Detect single cell voltage (14-16 strings) or total voltage (2 circuits).
Current Detection	Battery charging current, discharging current detection.
Temperature Detection	Total 8 circuits. 6 circuits for battery temperature detection, 1 circuit for Mosfet temperature detection, 1 circuit for battery internal ambient temperature detection.
Protection	overcharge protection, over discharge protection, over-voltage protection, high temperature protection, low temperature protection, short circuit protection and hardware fault protection, etc. with record function for the fault alarm and protection, which is convenient for after-sales viewing and analysis of problems.
Pre-charge Control	Charging low-voltage batteries with low current.
Pre-discharge Control	Pre-charge the inverter capacitors.
Interface	Same port .

1.5 Battery software upgrade

1.5.1 Upgrade via USB

1. Copy the upgrade file into the U disk.
2. Turn battery off, access U disk.
3. Turn on battery and successfully enter the upgrade state, the RUM led will blink for 3 seconds at the same time.
4. If the battery starts properly, the upgrade is complete.

Note: Choose the USB upgrade mode, there must be no other files in the U disk, otherwise the upgrade will not be possible or the upgrade error.

1.5.2 Upgrade via Inverter

1. Connect to WiFi monitor for remote upgrade through inverter.
2. The LCD displays the upgrade screen, and the SOC progress bar blinks once every 500ms.
3. When the SOC reaches 100%, the upgrade is complete.

Note: Inverter remote upgrade mode can only upgrade the battery host.

2 Safety

Safety information contains in this section must be observed at all times when working on or with batteries. For safety, installers are responsibility to familiarize themselves with this manual and all warnings before installation.

2.1 Application

Please read the product manual and the warning signs on the surface of the battery box carefully before using the battery. Improper use of the battery may cause overheating and damage to the battery. The company does not assume any responsibility for any accidents caused by improper operation. In order to use and dispose of the battery safely, please read the operating instructions carefully before use:

- Keep the batteries away from heat sources, high voltage places and long periods of sunlight exposure.
- Batteries must not be thrown into water or fire.
- Do not reverse the positive and negative terminals of the battery.

- Do not use metal to short the positive and negative terminals of the battery.
- Avoid excessive physical shocks and impacts to the battery, do not hit, drop or step on the battery.
- It is strictly forbidden to disassemble or assemble the battery privately without the permission and guidance of the manufacturer.
- Cannot mix other batteries of different manufacturers, types and models.
- Do not use or store in high temperature environments, as this may cause the battery to heat up, catch fire or have a reduced service life.
- Charge the battery promptly (within 15 days) after it runs out of charge.
- Please use the matching or recommended professional lithium battery charger.
- Stop using the battery if it has abnormal conditions such as odor, discoloration, noise, liquid leakage, or serious deformation.
- If electrolyte leaks into the skin or eyes, flush with water and seek immediate medical attention.
- Please place the battery out of the reach of pets and children, and prohibit children from touching the battery.
- Below 0°C, due to the low temperature performance of the battery, please reduce the power to use, a battery pack with a load of 2.5KW or less.

2.2 Safety Precautions

2.2.1 Environment requirements

- Do not expose the battery to temperature above 55°C ,or heat sources.
- Do not install or use the battery in wet locations, moisture , corrosive gases or liquids, such as bathroom.
- Do not expose the battery to direct sunlight for extended periods of time.
- Place battery in safe place away from children and animals.
- Battery power terminals shall not touch conductive objects such as wires.
- Do not dispose the batteries in fire, which may cause an explosion.
- The PACK shall not come in contact with liquids.
- The PACK can only be installed indoors. Regarding indoor installation, please do not install it in the bedroom, living room, kitchen, etc.

2.2.2 Operation and Precautions

- Do not touch the PACK with wet hands.
- Do not disassemble the PACK without permission.
- Do not crush, drop or puncture the PACK and battery.
- Dispose the batteries according to local safety regulations.
- Store and recharge battery in accordance with this manual.
- Ensure the connection of ground wire reliable.
- Remove all metal objects such as watches and rings that could cause a short-circuit before installation, replacement and maintenance.
- The Pack shall be repaired, replaced or maintained by skilled personal that has been recognized.
- When storing or handling batteries, do not stack batteries without package.
- Do not broke the battery, the released electrolyte may be toxic and is harmful to skin and eyes.
- Packaged batteries should not be stacked more than specified number stipulated on the packing case.
- Do not use damaged, failed or deformed batteries, which may lead to high temperature or even dangerous accidents. Continued operation of damaged battery may result in electrical shock, fire or even worse.

2.3 Warning labels

Symbols	Description
	Do not dispose in trash
	can be recycled
	Certification in European union area
	Electric shock hazard
	Explosive gas
	May leak corrosive electrolyte
	Heavy enough to cause severe injury
	Keep the Pack away from children
	Make sure the battery polarity well connected
	Do not expose to fire
	Operate according to Manual







  LiFePO ₄ Battery	
Model Name	Hope 14.3L-R1
Nominal Voltage	51.2V
Rated Capacity	280Ah
Rated Energy	14.3KWh
Max Charge Current	220A
Max Discharge Current	220A
Ingress Protection	IP20
Charge Temperature	0°C ~ 55°C
Discharge Temperature	-20°C ~ 55°C
Weight	120±2Kg
    X Made In China	

Figure 5: Nameplate

2.4 Emergency Responses

Manufacturer takes foreseeable risk scenarios into consideration and is designed to reduce hazards and dangers. However, if the following situation occurs, do as below:

Situation Occurs	Treatment Solution
Leakage	<ol style="list-style-type: none"> 1. Avoid touch of leaking liquid or gas. If you touch the leaking electrolyte, do as below immediately. 2. Inhalation: Evacuate the contaminated area, and seek medical help. 3. Eye contact: Rinse eyes with flowing water for 15 minutes, and seek medical help. 4. Skin contact: Rinse contacted area thoroughly with soap and water, and seek medical help. 5. Ingestion: Vomiting, and seek medical help.
Fire	If the battery is on fire, try to extinguish the fire with fire fighting sand and evacuate people due to the situation.
Wet Packs	If pack is flooded or submerged, do not use it. Contact Manufacturer for technical assistance immediately.
Damaged PACKS	Damaged pack are dangerous and must be handled with special attention. They are no longer suitable for use and may cause danger to people. If the pack damaged, stop use it and contact the manufacturer.

3 Storage and Transportation

3.1 Storage Requirements

Place the battery follow the identification on the packing case during storage.

Do not put the battery upside down or sidelong.

The defective pack needs to be separated from other Batteries.

The storage environment requirements are as follows:

- 1) Install the battery in a dry and clean place with proper ventilation.
- 2) The storage temperature for a short week is between -20°C to 45°C.
- 3) If you store the pack over a long period of six months, the storage temperature is between 0°C to 45°C, relative humidity: 10%~90%RH.
- 4) Place the battery away from corrosive and organic substances (including gas exposure).
- 5) Free from direct exposure to sunlight and rain.
- 6) At least two meters away from heat sources (such as a radiator), free from exposure to intensive infrared radiation.

If the battery has not been used for more than six months, it needs to be charged, the charging procedure is as follows:

- 1) Identify the PACK that needs charging.
- 2) Refer to quick installation guidance, complete the installation and wire connection. Ensure BATTERY in off status during all the steps.
- 3) Activating the inverter, activating the battery and starting charging.
- 4) When the RUN_LED is always on, the LCD SOC progress bar blinks, indicating that it is charging normally.
- 5) When the LCD SOC displays 100%, it is fully charged.

3.2 Transportation Requirement

PACK has been certified in UN38.3 (Section 38.3 of the sixth Revised Edition of the Recommendations on the Transport of Dangerous Goods: Manual of Tests and Criteria) and SN/T 0370.2-2009 (Part 2: Performance Test of the Rules for the Inspection of Packaging for Exporting Dangerous Goods). PACK is classified as category 9 dangerous goods.

The PACK shall not be transported with other inflammable, explosive or toxic substances; Ensure the original Package and label complete and recognizable.

Prohibit direct exposure to sunlight, rain, condensing water caused by temperature difference and mechanical damages.

There will be a drop in capacity during transportation and storage.

Transportation temperature is between-10°C to 45°C, relative humidity: 10%~90%RH.

4 Installation

Ensure to read the Guidance before installation in order to understand product information and safety cautions. Operators should be well trained technicians and fully understand the whole photovoltaic system, grid network, working principle and national regional standards.

Installers must use insulating tools and wear safety equipment.

Device damages caused by failure to comply with storage, transportation, installation and use requirements specified in Guidance are not covered by Warranty.

The PACK can only be installed indoors. Regarding indoor installation, please do not install it in the bedroom, living room, kitchen, etc.

Different types of batteries are not recommended to be mixed and used in parallel.

The battery system cannot be installed, dismantled, and maintained when it has been powered on.

4.1 Installation Environment

The ambient temperature for the installation of the battery system shall be above 0°C, below 40°C, and the humidity shall be between 10% -95%.

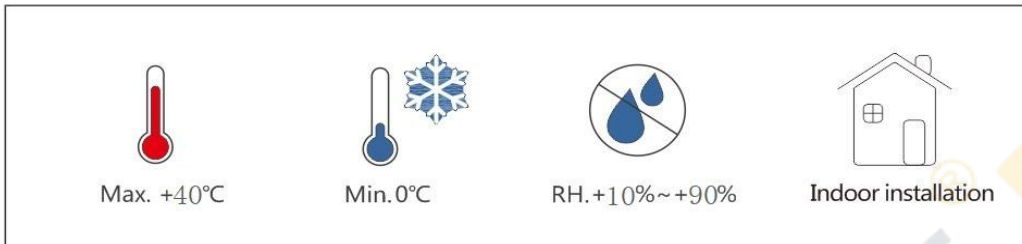
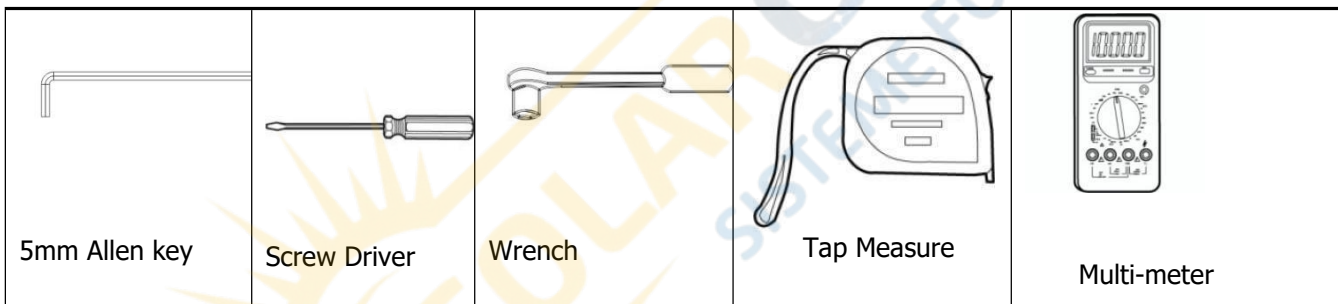

Figure 5: Installation Environment Requirements

4.2 Installation Required Tools

The following tools are required to install the pack:



It is recommended to wear the following safety gear when dealing with the pack.



4.3 Check

4.3.1 Pre-installation Check

Check the package	Check the PACK package before opening it, if any abnormality is detected, do not open the package and contact your supplier.
Check the power	Check and confirm the PACK is powered off before installation.

Check deliverable	Check the quantity of all parts inside according to the package list. If there is any part missing or damaged, please contact your distributor.
-------------------	---

4.3.2 Check Packing List

Hope 14.3L-R1 Battery Pack(Standard)			Hope 14.3L-R1 Battery Pack(Optional)			Batt-Intgr-Touch 7in LCD(Optional)		
Item No.	Part Name	Qty	Item No.	Part Name	Qty	Item No.	Part Name	Qty
1	Hope 14.3L-R1 Battery Pack	1 pcs	10	Hanger Component 1	2 pcs	14	LCD	1 pcs
2	User Manual	1 pcs	11	Hanger Component 1 screw(M5*10)	8 pcs	15	Network cable B	1 pcs
3	Network cable A	1 pcs	12	Hanger Component 2	1 pcs	16	screw	1 pcs
4	warranty card	1 pcs	13	Hanger Component 2 screw(M8)	16 pcs	17	User manual	1 pcs
5	SC35-8 lug	4 pcs				18	SD card	1 pcs
6	+ power cable	1 pcs						
7	+ power cable	1 pcs						
8	Castor	4 pcs						
9	Castor screw	16 pcs						

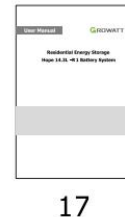
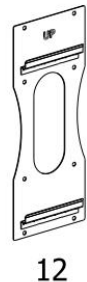
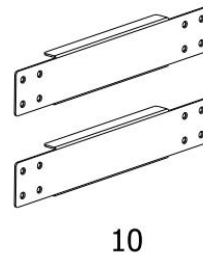
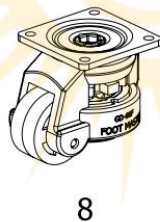
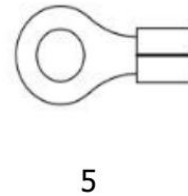

4.4 Installation

4.4.1 Battery Placement

1) Please install indoors and ensure the level of the ground.

2) The maximum quantity of stacking battery pack is 6, only support to horizontally mounted.

Make sure the batteries are mounted in the correct orientation. Please refer to the picture below (✓ means acceptable, X means unacceptable).

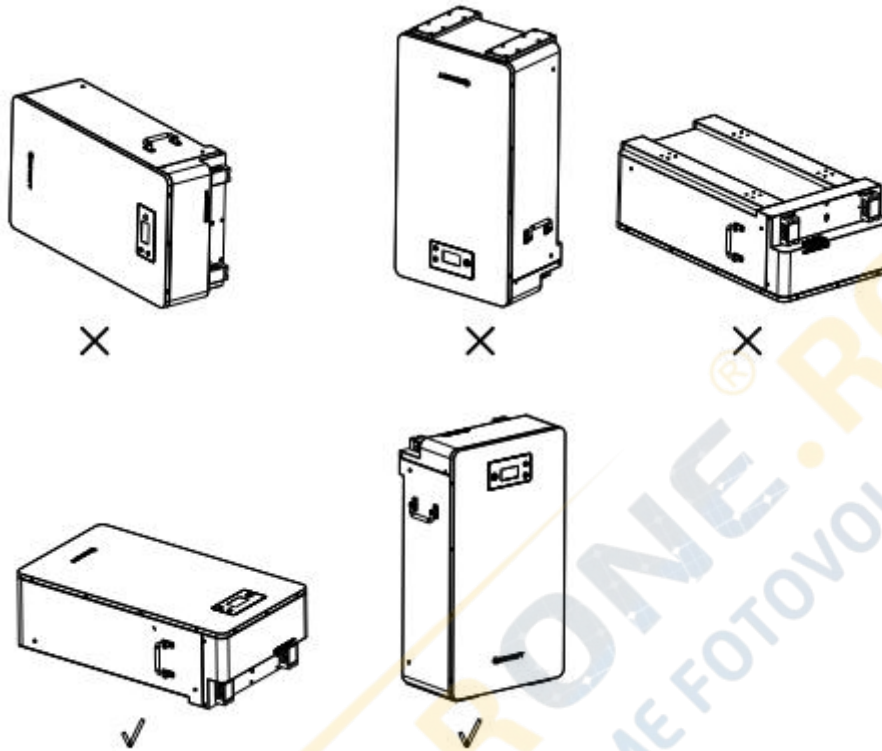

4.4.2 Communication Cable Communication

Please wear an anti-static wrist strap, anti-static gloves, and goggles.

It is recommended that the power line and communication line between the battery and the inverter should not exceed 2 meters.

inverter Communication interface definition:

Item	Crystal head picture	Serial no.	Definition
PCS		1	RS485_B
		2	RS 485_A
		3	GND_COM
		4	CAN_H
		5	CAN_L
		6	GND_COM
		7	Wake-
		8	Wake+(5v)

4.4.3 Single Battery Installation

Make sure the battery is in off mode and the battery breaker is off Ensure there are no tangled cables after battery wiring.

Step 1: Castor mounting

The four casters of the base are installed as shown in the figure.

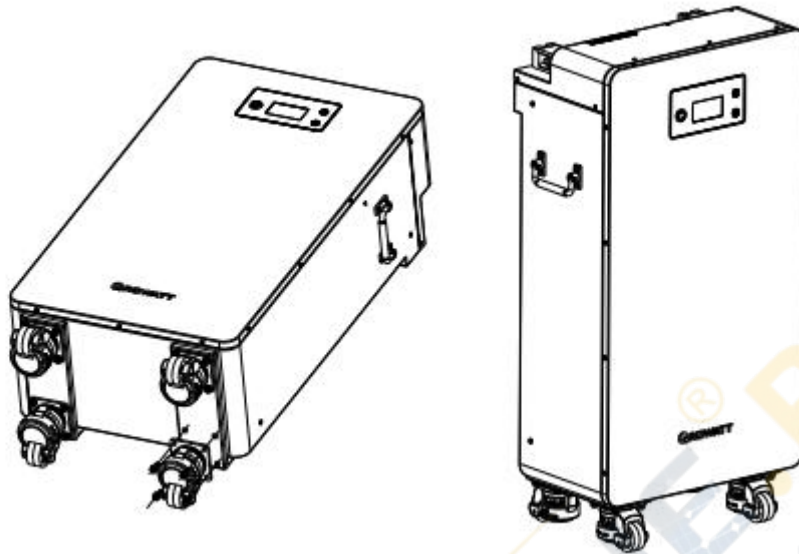

Figure 6: Caster installation diagram

Step 2: Install hanger component (optional)

Install hanger component 1 on the wall, use M8 explosive screw set.

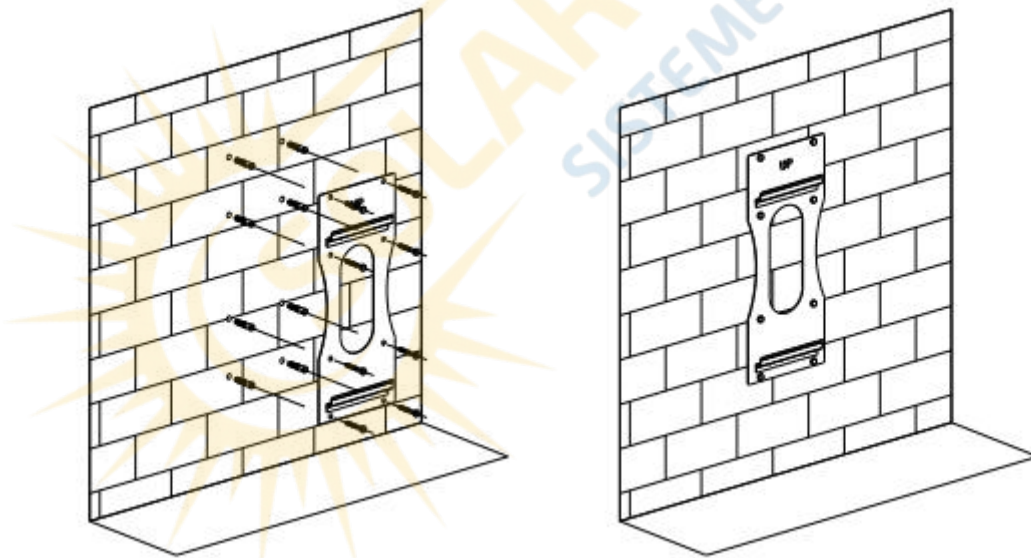

Figure 7: Component 1 Installation diagram

Install hanger component 2 on the battery.

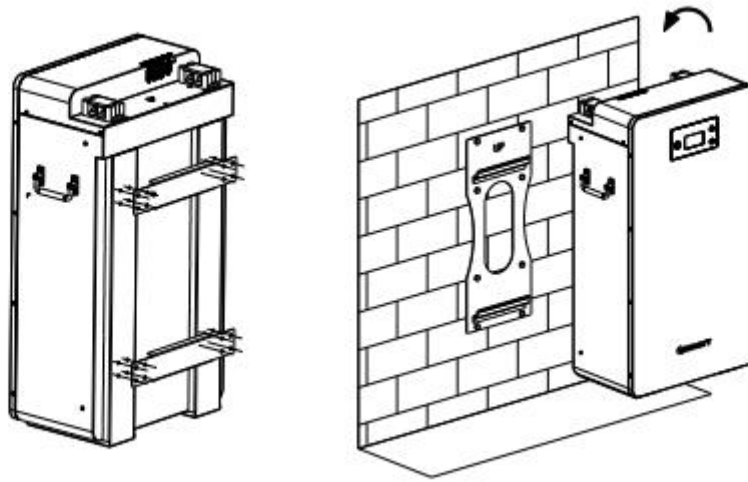

Figure 8: Component 2 Installation

Step 3: Install the battery into the card slot (optional)

After the wall mount is installed, it is shown in the following figure

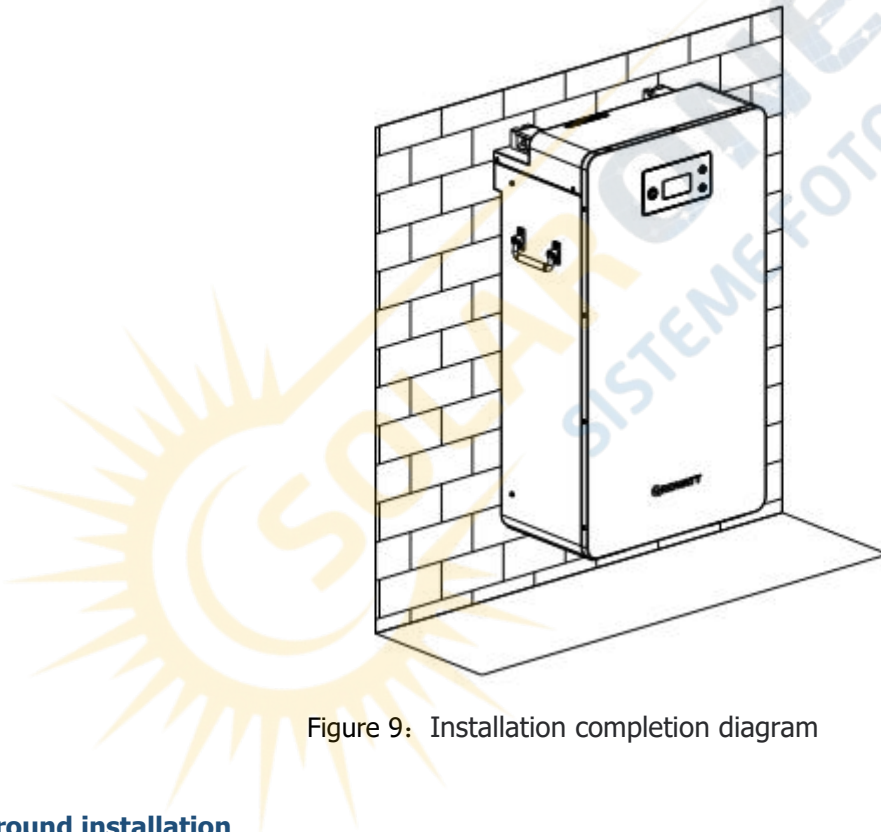

Figure 9: Installation completion diagram

Step 4: Ground installation

Fix the ground wire to the ground terminal with an M4 screw and fix the other end to the inverter. Note that the cross-sectional area of the ground wire is 16mm².

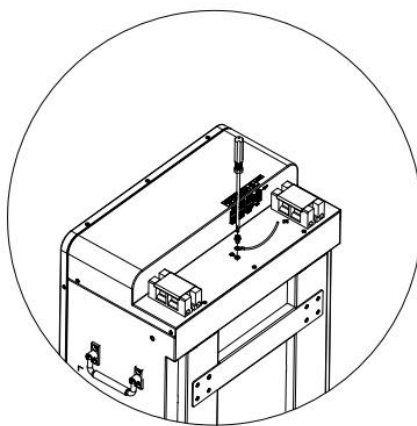

Figure 10: Ground diagram

Step 5: Insert the network cable into the battery port.

1. Insert network cable A into the inverter port of the battery, and the other end of the network cable into the network port of the inverter.

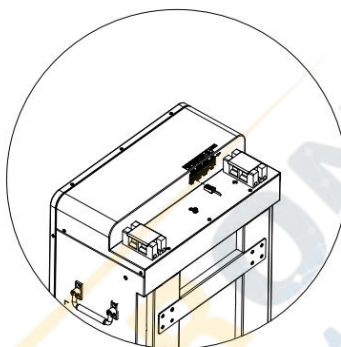

Figure 11: Network cable connection diagram

Step 6: Connecting Power Cable

1. Fix the OT terminal of the power cable to the pair of "+/-" terminals of the battery.
2. Put the plastic cover back.
3. Fix the other end to the breaker and then connect to the inverter.

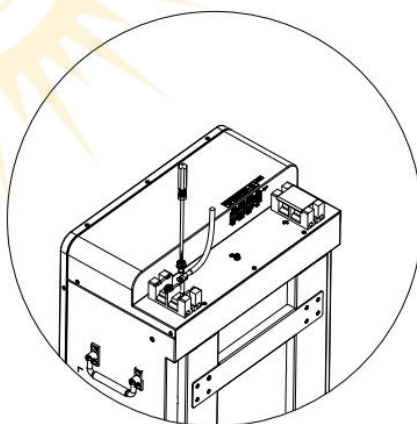

Figure 12: Power line connection diagram

When connecting the power cable, make sure the direction of OT terminal is correct. Don't stack two OT terminals on one power port.

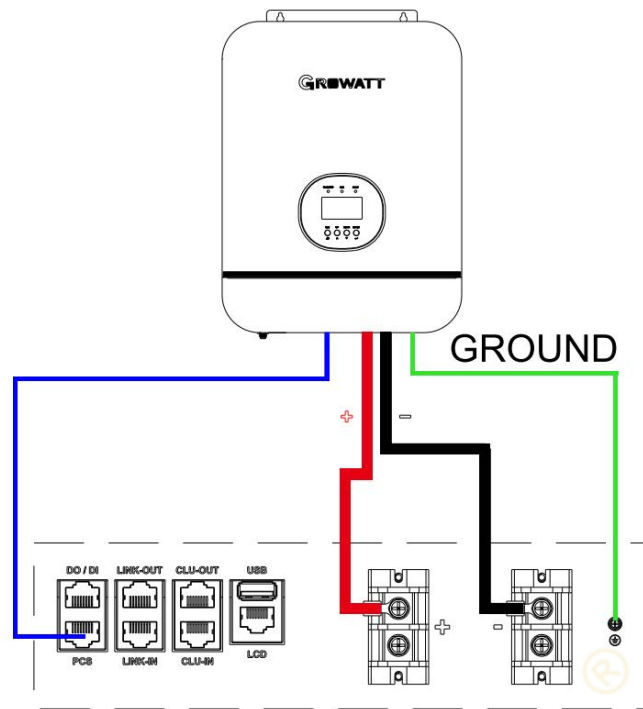

Figure 13: Single Battery Installation Diagram

- 1) The battery is not allowed to be wired in the running state, and the battery should all be off before installation.
- 2) Please install the communication line first, then protect the unused ports and USB ports against dust, and finally install the power cable.
- 3) To ensure the safety, don't forget to connect ground wire .
- 4) We recommend installing a circuit breaker between the inverter and the battery. For the specifications of the circuit breaker, we recommend using a molded case circuit breaker with a rated operating voltage greater than 80Vdc and a rated operating current greater than 250A.

4.4.4 Battery Capacity Expansion Installation

- * Ensure all batteries are in off mode and battery breaker are off.
- * Ensure there are no tangled cables after battery wiring.
- * Max Capacity Expansion parallel is 10pcs to creat a 14.3kw expanded energy storage system.

Step 1 Connect network cable

1. Insert the network cable A into the inverter port of battery 1, and the other end insert into the BMS network port of the inverter .Connect the first and last battery lines 2 to the inverter.
2. Use network cable B to connect the LINK-OUT port of battery 1 to the LINK-IN port of battery 2 , Connect the rest of the batteries in the same way until the last battery is connected.

Step 2 Connect Ground

Connect the ground terminal of each battery to the ground strip.

Step 3 Connect Power Cable

Connect the +/- terminals of each battery to the +/- terminals of the next battery, and then connect the wires to the inverter.

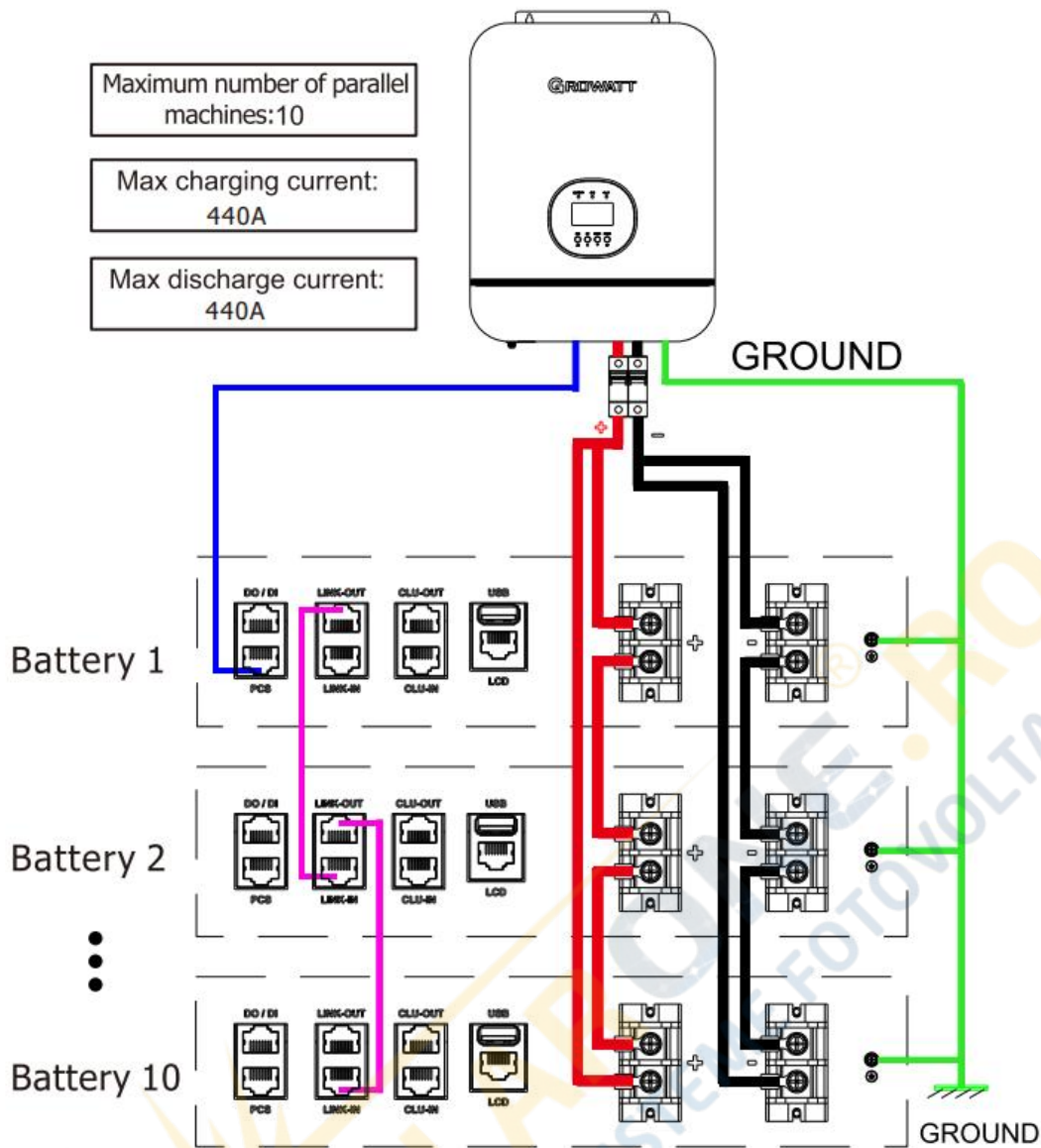

Figure 14: Capacity Expansion Installation Diagram

- 1) The battery is not allowed to be wired in the running state, and the battery should all be off before installation.
- 2) Refer to Figure 14 for power cable wiring.
- 3) Please install the communication line first, then protect the unused ports and USB ports against dust, and finally install the power cable.
- 4) We recommend installing a circuit breaker between the inverter and the battery. For the specifications of the circuit breaker, we recommend using a molded case circuit breaker with a rated operating voltage greater than 80Vdc and a rated operating current greater than 300A.

Note: When more than two batteries are connected in parallel, the maximum working current reaches 280 A. You are advised to connect the power cables of the first and last two batteries to the inverter to ensure more balanced charging and discharging of batteries and more security.

4.4.5 Battery Pack Power Expansion Installation

- * Make sure all batteries are in off mode and the battery circuit breaker is off.
- * Make sure there are no tangled cables after the battery wiring.
- * Max Output Power Expansion parallel is 8pcs to create a 57kw expanded energy storage system

Step 1: Connect Network Cable

1. Insert one end of the network cable A into the inverter interface of battery 1 and the other end into the BMS network port of the inverter.
2. Connect the LINK-OUT connector of battery 1 and the LINK-IN connector of battery 2 using network cable B. Connect the rest of the batteries in the same way until the last battery is connected.

Step 2: Connect the Ground Wire

Connect the ground terminal of each battery to the grounding strip.

Step 3: Connect Power Cable

Connect the +/- terminal of each battery into the +/- terminal of the latter battery separately, and then connect the wires to the inverter.

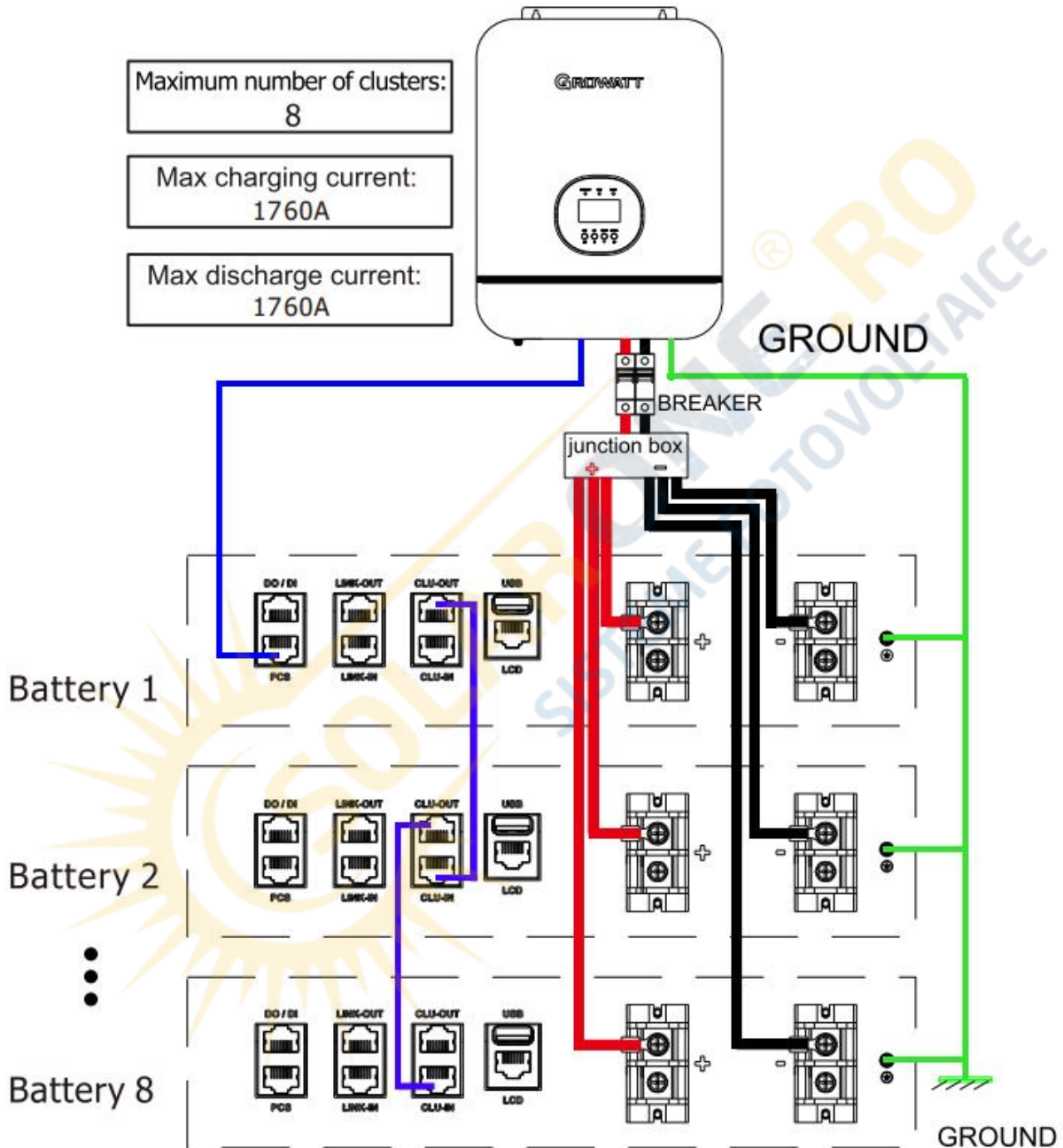

Figure 15: Installation Diagram for Power Expansion

- 1) The battery is not allowed to be wired in the running state, and make sure all batteries are in off mode before installation.
- 2) Refer to Figure 15 for power cable wiring.
- 3) Please install the communication line first, then protect the unused ports and USB ports against dust, and finally install the power cable.
- 4) We recommend installing a circuit breaker between the inverter and the battery. For the specifications of the circuit breaker, we recommend using a molded case circuit breaker with a rated operating voltage higher than

80Vdc, the rated working current is determined by the power.

It is recommended to connect a battery pack to a 140A circuit breaker, and connect multiple battery packs to 140A*n circuit breaker.

4.4.6 Battery Pack Capacity and Power Expansion Installation

- * Ensure all batteries are in off mode and battery breakers are off.
- * Ensure there are no tangled cables after battery wiring.
- * Support up to 48 battery packs connected in parallel to form a 114KW expanded energy storage system

Step 1: Connect The Network Cable

1. Insert one end of the network cable A into the inverter interface of battery 1 and the other end into the BMS network port of the inverter.
2. Connect the LINK-OUT connector of battery 1 and the LINK-IN connector of battery 2 using network cable B. Connect the rest of the batteries in the same way until the last battery is connected.
3. Connect CLU-OUT port of master battery in main cluster and CLU-IN port of master battery in Slave Cluster, connect rest of batteries in the same way until the last battery is connected.

Step 2 Connect The Ground Wire

Connect the ground terminal of each battery to the grounding strip.

Step3 Connect The Power Cord

Connect the +/- terminal of each battery into the +/- terminal of the Junction box separately, and then connect the wires to the inverter.

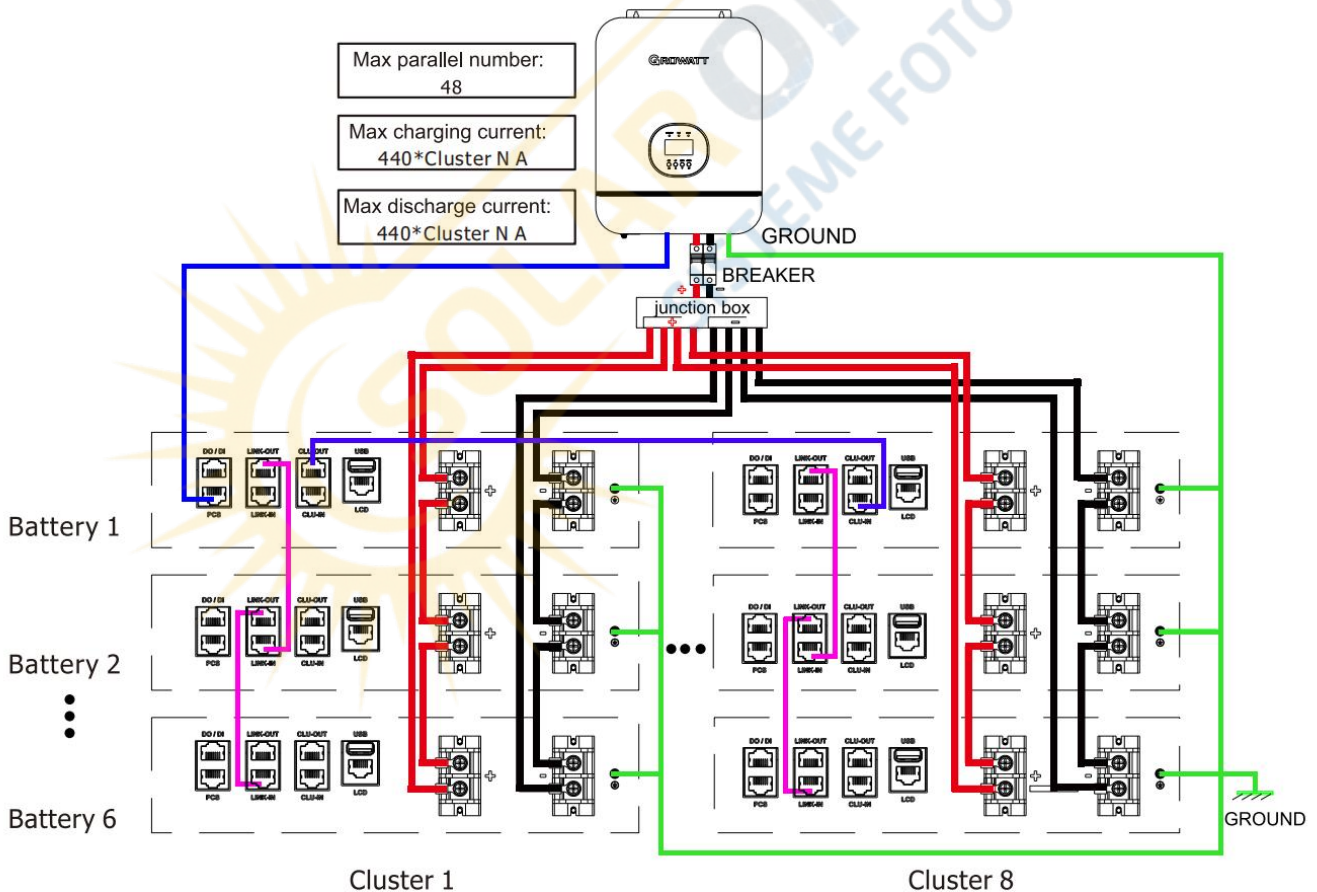

Figure 16: Installation Diagram for Capacity Expansion

- 1) The battery is not allowed to be wired in the running state, and the battery should all be off before installation.
- 2) Refer to Figure 16 for power cable wiring.
- 3) Please install the communication line first, then protect the unused ports and USB ports against dust, and finally install the power cable.

4) We recommend installing a circuit breaker between the inverter and the battery. For the specifications of the circuit breaker, we recommend using a molded case circuit breaker with a rated operating voltage higher than 80Vdc, the rated working current is determined by the power.

It is recommended to connect a battery pack to a 140A circuit breaker, and connect multiple battery packs to 280A*n circuit breaker.

5 Power on/off

The installation and use of batteries involve much specialized knowledge. Therefore, technicians should be given appropriate technical training and obtain operational certificates in compliance with local laws and regulations.

Please ensure technicians have obtained training certificate before operation.

Please stand on dry insulating objects and do not wear conductive material such as watches and necklace during operation. Insulated tools should be used.

Do not contact any positions with voltage potential difference.

Prohibition sign should be hung on the battery: " Non-professionals, do not touch" .

If any abnormalities occur during the startup phase, power off the pack immediately. After problem confirmed, proceed again.

Make sure the inverter is turned off before checking the pack.

5.1 Power on

When multiple batteries are connected in parallel or multiple clusters of batteries are connected in parallel, press one of the battery power buttons and all the batteries connected in parallel can be turned on.

Power on the PACK by pressing power button($t > 1S$)		
Item	procedures	Acceptation criteria
1	Connect battery and inverter	Make sure the wiring harnesses are well connected.
2	Turn on breaker of battery	Make sure breaker of battery is ON.
3	Press power switch for 1 second and observe LED and LCD indication on panel	1. if indication of RUN and SOC is ON, pack is powered on successfully. If the LCD displays the fault code and the MOS is not turned on, it indicates that the packaging has a fault and should be solved before restarting.
Power on pack by inverter		
1	Connect inverter and battery	Make sure the wiring harnesses are well connected.
2	Turn on breaker of battery	Make sure breaker of battery is ON
3	Power on inverter for charging battery	1. if indication of RUN is ON, pack is powered on successfully. 2. If the LCD displays the fault code and the MOS is not turned on, it indicates that the packaging has a fault and should be solved before restarting.

5.2 Power off

Press the power switch for 3 seconds and release it, battery off, LED lights off. If multiple batteries are connected in parallel, only press the power switch of any one of the batteries for 3 seconds and then release it, the other batteries can be turned off.

6 Maintenance Guide

6.1 Preparation

Tools like safety gloves, cross head driver and socket wrench should be prepared.

Turn off and turn on new PACK .

1. If the PACK is power-off. Press power button for 1 second to turn on.
2. If the PACK is power-on. Press power button 3-5 seconds to turn off.

Before maintaining the battery, turn off the breaker and press power button 3-5 seconds to make sure the battery is power-off. Follow the installation and wire connection procedures specified above. Ensure wires are properly connected before turn the breaker on. After that, turn on the breaker and press power button of any battery for 1 second to check if the system normal works.

6.2 Battery Replacement

Wear safety gloves.

Open the breaker and power off the battery.

Remove your safety screw under the power supply, and disconnect the power cord and CAN.

communication line of the battery.

Remove the safety part at the left end of the battery and lift the battery upward.

Put the battery into the packing box according to the repair procedure and transport the battery to the designated repair site.

Install new battery based on procedure specified in Section 4.

6.3 System Failure Information List and Trouble Shooting Suggestions

Error code	Error Description	Error Cause	Suggested Actions
2	Discharge under voltage protection	Cell voltage / battery voltage below the threshold of under voltage protection	there is no safety risk, but user should stop discharging and arrange charging,
3	Charge over voltage protection	cell voltage / battery voltage above the threshold of over voltage protection	There is safety risk.user should stop charging,and make it in idle or discharging until recoving to normal status.
60	External communication failure	Failed communication for battery and inverter	there is no safety risk, but user should stop using. Check whether communication between inverter and battery is normal. if battery and inverter communication failed, but ensure communication wire connection well. please contact installer for repairing battery.

59	Internal communication failure	Communication loss of two battery packs in parallel	Check CAN connection of link-in and link-out between two battery PACKS.
10	Parallel failure	There is alarm in parallel mode	Check CAN connection of batteries. Check wire connection of batteries.
6	Dicharge short circuit	External short circuit of battery	Safety risk exist,please stop using it. User need contact installer for repairing
21	Pre-charge short circuit		
20	Pre-charge timeout		
9	Parallel ver failure	Different firmware version	Safety risk exist,please stop using it. User need contact installer for updating the same firmware version
36	Main circuit fault	BMS main power circuit fault	Safety risk exist,please stop using it. User need contact installer for repairing
12	MOS control fault	After turn off mosfet, there is still current.	Safety risk exist,please stop using it. User need contact installer for repairing



7 Technical Specifications

Functional parameters of Hope14.3L-R1 are as below:

No.	Items	Specification
1	Battery Module	Hope 14.3L-R1
2	Rated Capacity/Energy	280Ah/14.3kWh
3	Nominal Voltage	51.2V
4	Operating voltage	40 – 58.4V
5	Max.charging current(25°C)	220A
6	Max.discharging current(25°C)	220A
7	Max peak current	700A 200us
8	Battery Type	LiFePO ₄
9	Operative Charging Temperature Range	0°C~55°C
10	Operative Discharging Temperature Range	-20°C ~55°C
11	Storage Conditions	-20 ~ 45°C Recommended storage temperature: 0~45°C Storage environment humidity ≤90%ROH, no condensation
12	Cooling	Natural Cooling
13	Dimension(W / D / H)	478/ 265 / 812 mm
14	Weight	120±2kg
15	Installation Type	Floor or wall hanging
16	Ingress Protection	IP 20
17	Safety Certificate	CE(EMC)/UN38.3/MSDS/ROHS/IEC 62619
18	Communication port	CAN/RS485
19	Max.Parallel number	48 pcs

Appendix 1 Fault code table

code		remark
protects		
1	bright	Software startup failure
2	bright	Total voltage low protection
3	bright	Total voltage high protection
4	bright	Single voltage low protection
5	bright	Single voltage high protections
6	bright	Short-circuit protection
7	bright	Charging current large protection
8	bright	Discharge current large 1 protection
9	bright	Parallel version inconsistency protection
10	bright	Parallel failure protection
11	bright	Large internal and external pressure difference protection
12	bright	MOS tube control fail-safe
13	bright	Low charging temperature protection
14	bright	Low discharge temperature protection
15	bright	High charging temperature protection
16	bright	High discharge temperature protection
17	bright	Parallel Charge over current protection
18	bright	Parallel Discharge over current protection
19	bright	parallel address is identical
20	bright	Pre-charge failure
21	bright	Pre-charge short circuit
22	bright	AFE is offline
23	bright	Cell voltage offline
24	bright	cell temperature offline
25	bright	Total voltage sampling failure
26	bright	Temperature short circuit
27	bright	External total pressure sampling failure
28	bright	Parameter loading failed
29	bright	AFE over voltage protection
30	bright	AFE under voltage protection
31	bright	AFE charge over current protection
32	bright	AFE discharge over current protection
33	bright	Large master/slave pressure difference
34	bright	cluster Charging over current protection
35	bright	cluster discharge overs current protection
36	bright	The main circuit is open
37	bright	Discharge over current 2 protection
38	bright	MOS tube over temperature protection

39	bright	Single pressure differential protection
40	bright	Single large temperature difference protection
41	bright	High ambient temperature
42	bright	Versions between clusters are inconsistent
43	bright	Inter cluster heavy sign fault
44	bright	AFE charging over temperature
45	bright	AFE charging low temperature
46	bright	AFE discharging over temperature
47	bright	AFE discharging low temperature
alarm		
51	flicker	SOC lows
52	flicker	The total voltage is too low
53	flicker	The total pressure is too high
54	flicker	The voltage of the unit is too low
55	flicker	The voltage of the unit is too high
56	flicker	Shutdown alarm
57	flicker	The charge over current alarm is generated
58	flicker	The discharge over current 1 generates an alarm
59	flicker	The internal can is disconnected
60	flicker	The external communication is offline
61	flicker	Large internal and external pressure difference alarm
62	flicker	none
63	flicker	Low charging temperature
64	flicker	Low discharging temperature
65	flicker	high charging temperature
66	flicker	high discharging temperature
67	flicker	Charge over power
68	flicker	Discharge over power
69	flicker	Charge circulation warning inside the system
70	flicker	System internal discharge circulation warning
71	flicker	The temperature of the MOS tube is too high
72	flicker	The unit pressure difference is large
73	flicker	Large single temperature difference
74	flicker	No DC current alarm is generated
75	flicker	ambient temperature is too high
76	flicker	inter cluster communication failed
77	flicker	MCU short circuit
78	flicker	EET short circuit
79	flicker	none
80	flicker	The number of parallel machines is too large

Appendix 2

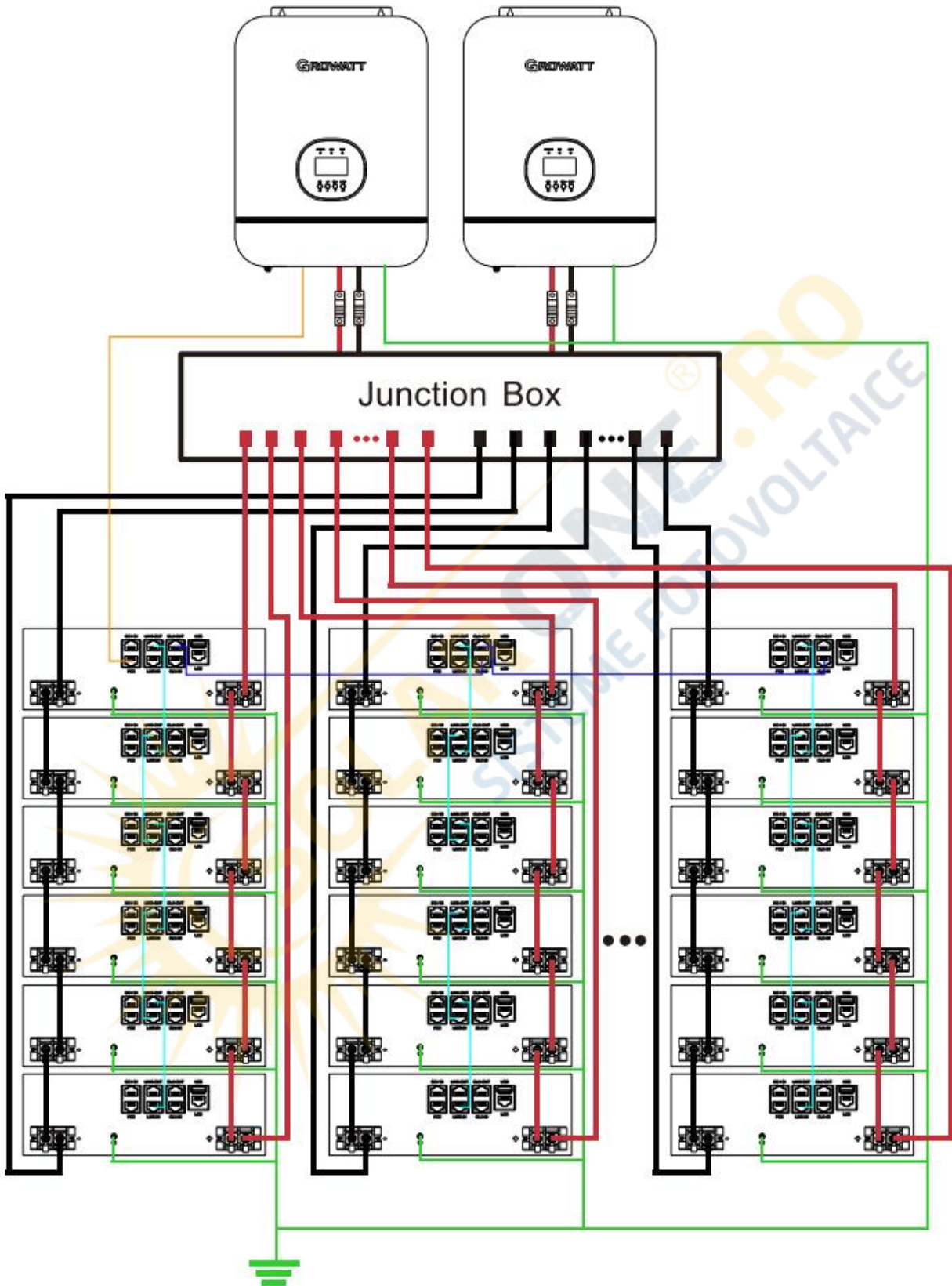

Figure 17: Parallel machines effect drawing